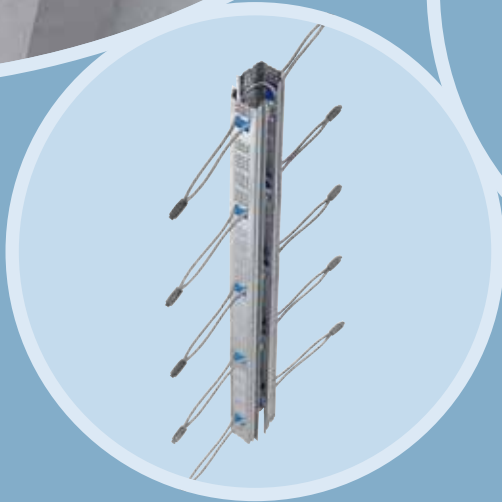


# VS<sup>®</sup>-ISI System

Wire rope loop rails for  
the connection of precast  
concrete elements

**PFEIFER**




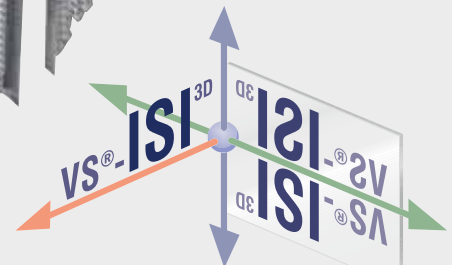
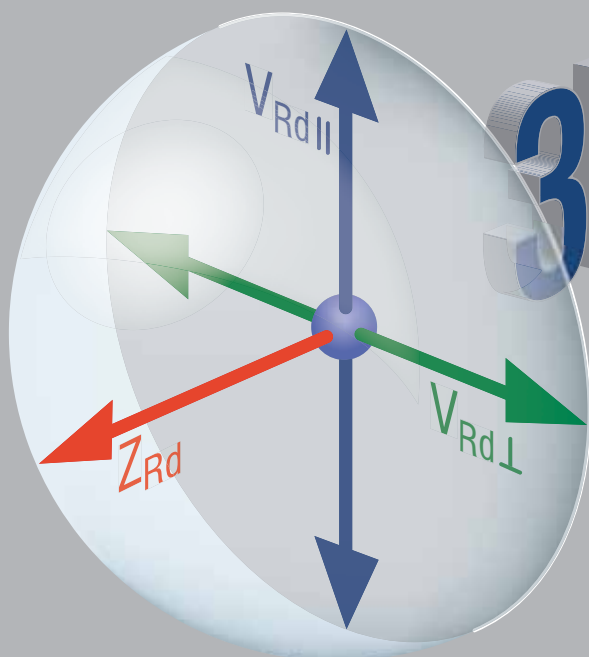
planning & installation

# Impressive application safety and performance – PFEIFER-VS<sup>®</sup>-ISI rails



## Advantages

- Building authority approval with very high security standard in case of fire 
- One design resistance for all mortars
- Free dimensioning software
- Optimum joint geometries – less mortar needed
- Huge variety of applications due to approved mortar – even in case of fire
- Design resistances in every direction – now in case of fire, too
- 3D forces
- VS<sup>®</sup>-ISI System – wire rope loop rails for connection
- Symmetrical rail profiles – NO directional installation
- Clear marking with colour-coded clips
- No additional formwork measures – Profiles form the complete joint profile
- Tested and approved for wall thicknesses from 140 mm



# PFEIFER-VS<sup>®</sup>-ISI System<sup>3D</sup>



**PFEIFER**

Reinforcement Systems  
VS<sup>®</sup>-ISI-System<sup>3D</sup>

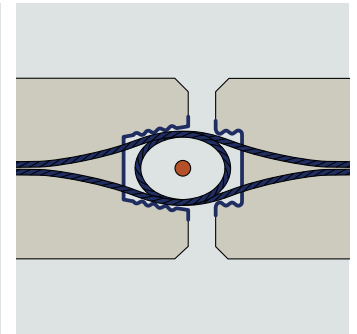
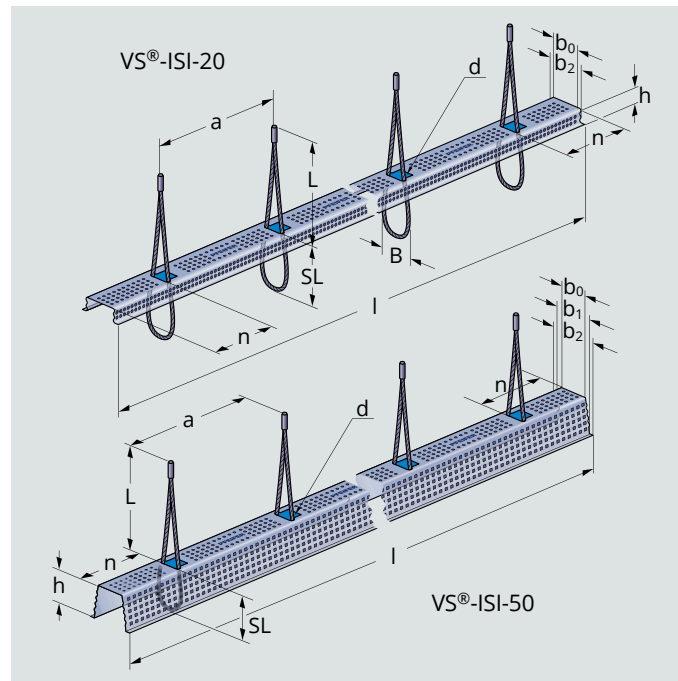
The PFEIFER-VS<sup>®</sup>-ISI System<sup>3D</sup> is used for the load bearing connection of precast wall panels and columns as well as wall-wall connections. Shear forces parallel and perpendicular to the joint as well as tensile force are regulated by the building authorities. Both grouting materials and joint filling mortars with plastic/thixotropic properties are available as joint filling materials in accordance with the approval.

### Advantages

- Practical solution for connecting precast elements
- Maximum process reliability
- Can be installed in any direction
- Maximum vertical tolerance
- Same design resistance for all grouts and filling mortars

### Materials:

- Rail: steel sheet galvanized  
Steel rope: high-strength, galvanized  
Cover: tape



Ref. no.	Type	Dimensions										Loops Quantity	Packing unit [no. of items]	Weight approx. [kg/piece]	
		b <sub>0</sub>	b <sub>1</sub>	b <sub>2</sub>	h	l	SL	L	a	n	B				d
		[mm]	[mm]	[mm]	[mm]	[mm]	[mm]	[mm]	[mm]	[mm]	[mm]	[mm]			
245321	VS <sup>®</sup> -ISI-20	50	-	70	20	1180	80	227	236	118	60	3	5	100	1,32
245477	VS <sup>®</sup> -ISI-50	50	65	80	50	1180	80	227	236	118	60	3	5	60	1,66
257382	Replacement tape for cut rails		50m m roll, silver grey, 78 mm wide												
141390	Replacement tape for cut rails		50m m roll, silver grey, 96 mm wide												



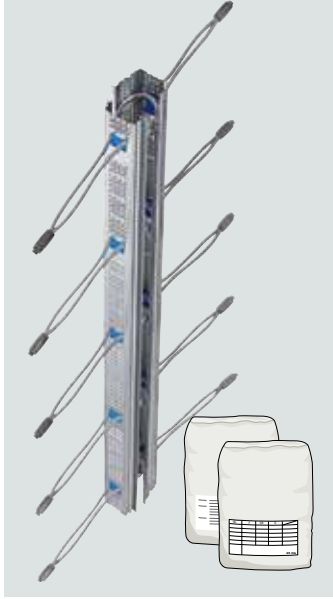
The grouting channel can be economically extended without loops using VS<sup>®</sup>-ISI empty profiles. These can be cut to size individually using an angle grinder. Additional formwork is then no longer necessary.

Ref. no.: 287840 (type VS<sup>®</sup>-20/000)  
287786 (type VS<sup>®</sup>-50/000)

# Instructions for use

## System description

**Figure 1:** VS®-ISI System<sup>3D</sup>

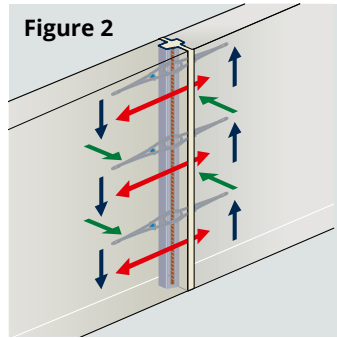


The PFEIFER-VS®-ISI System<sup>3D</sup> (Fig. 1) is designed for the connection of steel reinforced concrete precast wall elements or steel reinforced concrete walls and columns. According to building authority approvals, the user has a choice of different materials with appropriate properties for filling the joints.

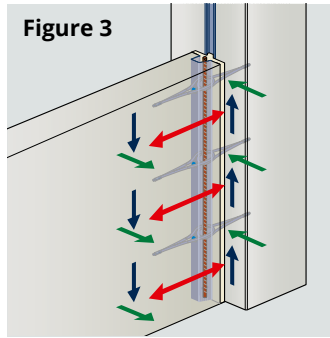
The connections are approved from component thicknesses of 140 mm for predominantly stationary **stresses from all three directions (3D)** (Figs. 2 and 3). In the case of a right-angled joint (Figs. 5 and 6), the thickness of the joined wall can be reduced to 100 mm. The PFEIFER-VS®-ISI System<sup>3D</sup> can be used according to Figs. 4 to 7.

Permissible stress directions: Tensile forces and shear forces parallel and perpendicular to the joint.

**Figure 2**

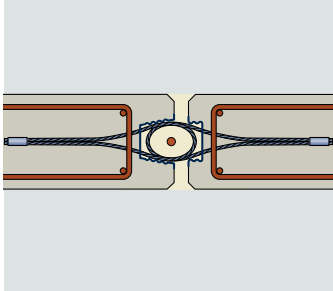


**Figure 3**

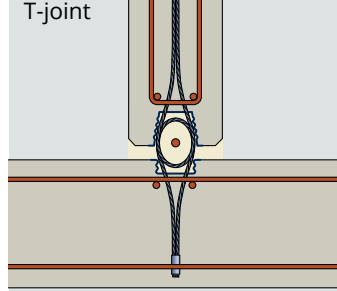


## Intended use

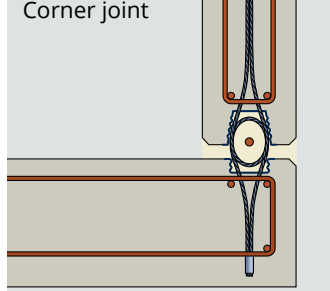
**Figure 4:** Wall butt joint



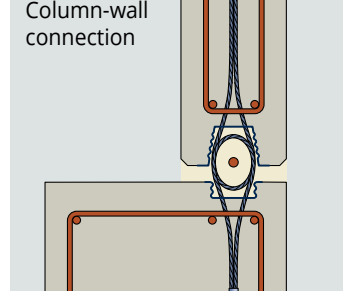
**Figure 5:** T-joint



**Figure 6:** Corner joint



**Figure 7:** Column-wall connection

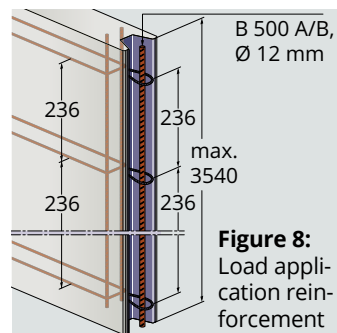


## Reinforcement

Reinforcement according to Figs. 8 and 9 must be installed in the reinforced concrete elements for the VS®-ISI System<sup>3D</sup>. If a corresponding reinforcement is already provided for other structural reasons, this can be credited.

## Surface reinforcement

Additional reinforcement and surface reinforcement are not covered by the approval and must be defined by the relevant planners according to the static conditions.



**Figure 8:** Load application reinforcement

## Links

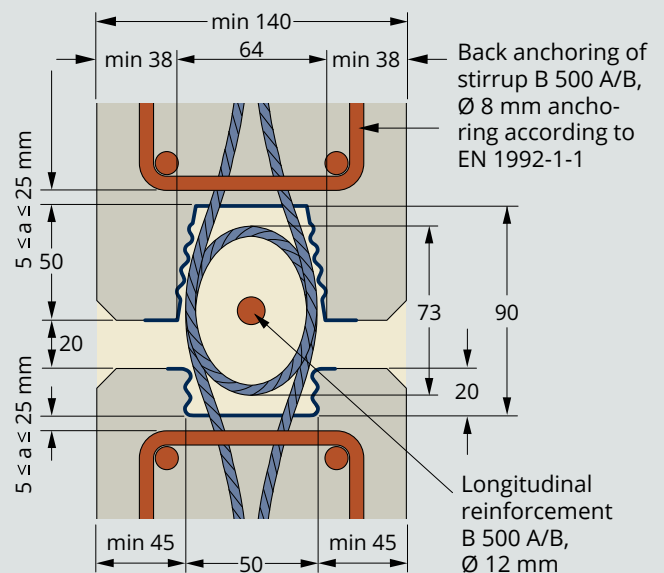
Ø 8 mm stirrups are to be provided every 236 mm (Figs. 8 and 9). The required anchoring lengths and the concrete covers to be provided must be determined by the responsible planner depending on the concrete quality used.



**Note:**

As an alternative to the stirrups, a suitable mesh cap Q257A can also be provided.

**Figure 9:** Principle sketch VS®-ISI



# Instructions for use

## Structural reinforcement

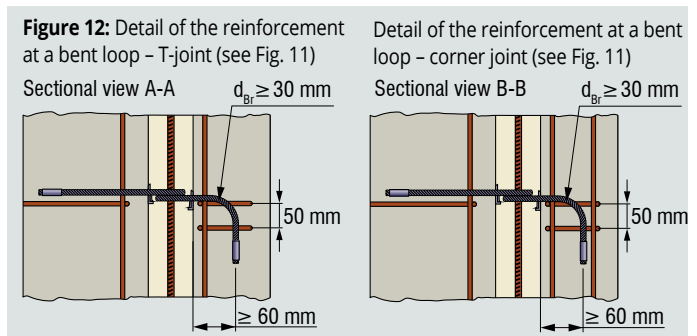
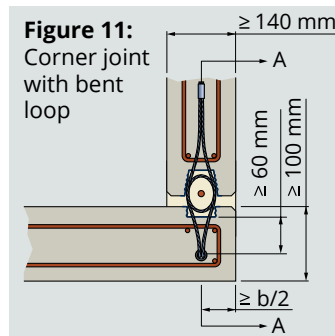
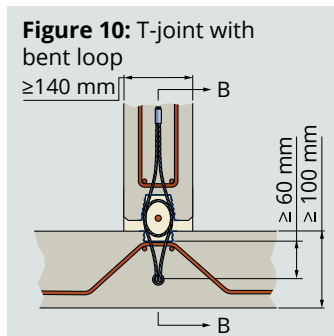
It is recommended to continue the surface reinforcement into the side flanks to the right and left of the rail profiles in order to protect them structurally against damage. In addition, continuous corner reinforcements ( $\varnothing$  10 mm) are also recommended.

## Joint reinforcement

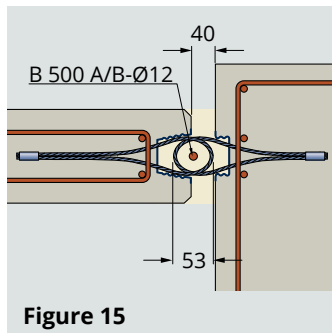
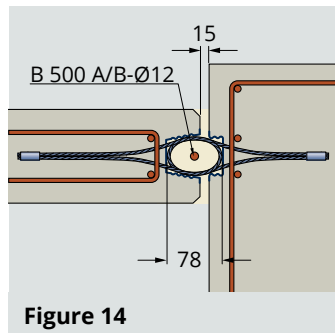
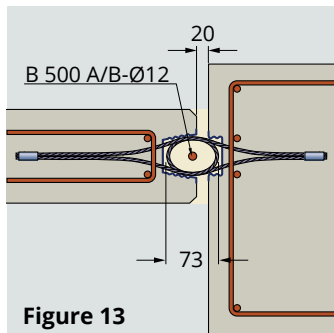
Before backfilling the joint, a reinforcement bar with a diameter of 12 mm must be inserted over the entire height of the joint in the area of the loop overlap (Figs. 8 and 9). This reinforcement bar is mandatory for reasons of statics, as it serves as a splitting tensile reinforcement in the joint.

## Bending the anchoring loop

When the elements have small dimensions, the anchoring loop of the VS<sup>®</sup>-ISI<sup>3D</sup> can be bent. The crucial factor here are the bending dimensions given, for example, in Figs. 10 to 12. At a corner joint, a  $\varnothing$  8 mm stirrup is to be installed in the region of the bent loop (Fig. 11).

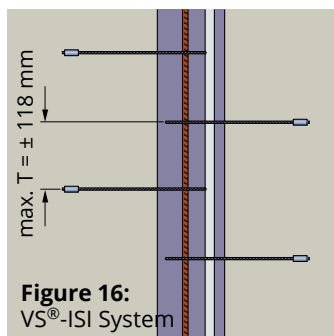


## Element joints



Standard joint = 20 mm (Fig. 13)  
 Minimum joint = 15 mm (Fig. 14)  
 Maximum joint = 40 mm (Fig. 15)

## Tolerance



In the normal case the joint must be planned in the vertical direction without offsetting the loops (Fig. 16). If the joints extend over a number of floors, it may in some circumstances be useful to set regular zero points for orientation of the rail sections.

**!** Maximum vertical tolerance (Fig. 16):  
 VS<sup>®</sup>-ISI System: max. T = ± 118 mm

# Dimensioning

The precast concrete elements being connected must be construed by a responsible planner in a minimum concrete grade of C 30/37 in accordance with EN 1992-1-1. Connections made with the VS®-ISI System<sup>3D</sup> are seen as reinforced joints with design resistances for tensile and transversal shear forces. Corresponding design resistances are listed in Table 1. When dimensioning the connection, the evidence for each load direction must be kept individually. Note here that, in addition to the tensile forcing acting from outside, the tensile forces resulting from the acting shear forces must be taken into account. If no external tensile force should be applied, a simplified analysis via an interaction diagram in accordance with the approval can be used. The acting expansion forces then need to be validated. Crack widths as a result of constraining forces must be limited in accordance with EN 1992-1-1. The approval Z-21.8-1929 applies.

**Table 1:** Dimensioning values for VS®-ISI System<sup>3D</sup>

Wall thickness [cm]	Design resistance – shear force, perpendicular $V_{Rd,\perp}$ [kN/m]				Design resistance – shear force, parallel $V_{Rd,\parallel}$ [kN/m]	Design resistance – tensile force $Z_{Rd}$ [kN/m]
	C 30/37	C 35/45	C 40/50	C 45/55		
14	9,7	11,1	11,9	12,6	60	36 <span style="color:red">28</span>
16	12,7	14,4	15,5	16,5	60	36 <span style="color:red">28</span>
18	15,9	18,1	19,4	20,7	60	36 <span style="color:red">28</span>
20	19,3	21,9	23,5	25,1	60	36 <span style="color:red">28</span>
22	22,8	26,0	27,9	29,7	60	36 <span style="color:red">28</span>
24	26,6	30,3	32,5	34,6	60	36 <span style="color:red">28</span>
26	30,5	34,8	37,3	37,5	60	36 <span style="color:red">28</span>
28	34,6	37,5	37,5	37,5	60	36 <span style="color:red">28</span>
≥ 30	37,5	37,5	37,5	37,5	60	36 <span style="color:red">28</span>

blue dimensioning values when using grouting material

red dimensioning values when using plastic/thixotropic material (possible materials according to p. 10)

## Verification method in cold case

### Shear force parallel to the joint

The design resistance of the shear force parallel to the joint  $v_{Rd,\parallel}$  according to Table 1 can be used in the limit state of the carrying capacity for the shear force parallel to the joint reinforced with the VS®-ISI<sup>3D</sup>.

$$\frac{v_{Ed,\parallel}}{v_{Rd,\parallel}} \leq 1,0$$

$v_{Ed,\parallel}$  [kN/m]: Parallel shear force per metre of joint  
 $v_{Rd,\parallel}$  [kN/m]: Design resistance of the parallel shear force per metre of joint

### Parallel and perpendicular shear forces combined

When shear forces perpendicular and parallel to the joint act simultaneously, the interaction of the shear forces is to be verified by means of the interaction relationship shown in the diagram (Fig. 17).

#### Interaction

all joint filling materials

### Shear force perpendicular to the joint

The design resistance  $v_{Rd,\perp}$  according to Table 1, depending on the component thickness and concrete strength class, can be used in the limit state of the carrying capacity for the shear force perpendicular to the joint reinforced with the VS®-ISI<sup>3D</sup>.

$$\frac{v_{Ed,\perp}}{v_{Rd,\perp}} \leq 1,0$$

$v_{Ed,\perp}$  [kN/m]: Acting shear force perpendicular per metre of joint length  
 $v_{Rd,\perp}$  [kN/m]: Design resistance of shear force perpendicular of the joint per metre

**!** 4 wire rope loops may be used per metre. VS®-ISI:  $Z_{Rd}$  per single loop 9 kN/7 kN

Expansion forces result from stresses perpendicular to the joint. These tensile forces can be absorbed either by the VS® wire rope loops or by appropriately arranged additional reinforcement or other structural measures and verified. The possibilities to verify the tensile forces are outlined below.

$$v_{Rd,\perp} [\% \text{ from the table 1}]$$

**Figure 17:** Interaction diagram – VS®-ISI System<sup>3D</sup>

## Tensile forces across the VS<sup>®</sup> loops

The different load directions result in individual tensile force components that act in the direction of the wire rope loop (Table 2). The sum of these individual components and any acting "external" tensile force (total tensile force) is verified on the basis of the tensile force resistance  $Z_{Rd}$  of the VS<sup>®</sup>-ISI System<sup>3D</sup> according to Table 1.

**Table 2:** Tensile force components ISI

Stress from parallel shear force	Perpendicular shear force $V_{Ed,II}$	Perpendicular shear force $V_{Ed,L}$	"Outer" tensile force
ISI tensile force components	$Z_{Ed,VI} = 0,5 \cdot V_{Ed,II}$	$Z_{Ed,V\perp} = 0,25 \cdot V_{Ed,L}$	$Z_{Ed,N}$

Verification of the total tensile force:

$$Z_{Rd} = n \cdot Z_{Rd}$$

$$Z_{Rd} \geq Z_{Ed,VI} + Z_{Ed,V\perp} + Z_{Ed,N}$$

$Z_{Rd}$  [kN/loop] : Design resistance of a loop

$Z_{Rd}$  [kN/m] : Design resistance of the tensile force per metre of joint according to Table 1/2, where  $n = 4$  wire rope loops per metre

$Z_{Ed,N}$  [kN/m] : Acting "outer" tensile force per metre of joint

$Z_{Ed,VI}$  [kN/m] : Expansion force from shear force parallel per metre of joint

$Z_{Ed,V\perp}$  [kN/m] : Expansion force from shear force perpendicular per metre of joint

## Special case: tensile forces without consideration of the wire rope loops

Only in special cases are the VS<sup>®</sup> wire rope loops not used for the transmission and forwarding of tensile forces; instead, the sum of the tensile forces  $Z_{Ed}$  is assigned to suitable tensile elements or other structural measures. This can be tensile elements (e. g. ring anchors) or other structural measures (clamped supports, frictional forces in the case of fully erect wall elements, or similar). The tensile forces resulting from the individual load directions are shown in Table 3.

**Table 3:** Tensile components for special case

Stress from	Perpendicular shear force $V_{Ed,L}$	"Outer" tensile force
Tensile force component	$Z_{Ed,V\perp} = 0,25 \cdot V_{Ed,L}$	$Z_{Ed,N}$

$$Z_{Ed} = Z_{Ed,V\perp} + Z_{Ed,N}$$

$Z_{Ed}$  [kN/m] : Total tensile force per metre of joint

$Z_{Ed,N}$  [kN/m] : Acting "outer" tensile force per metre of joint

$Z_{Ed,V\perp}$  [kN/m] : Expansion force from shear force perpendicular per metre of joint

# Dimensioning under the effects of fire



The PFEIFER VS®-ISI System may be used in components for the following fire protection requirements:

**Table 4:** Fire resistance class

Building authority requirement	DIN 4102	DIN EN 13501
fire-retardant	F30	REI 30
highly fire-retardant	F60	REI 60
fire-resistant	F90	REI 90
Fire wall	Fire wall	REI 90-M

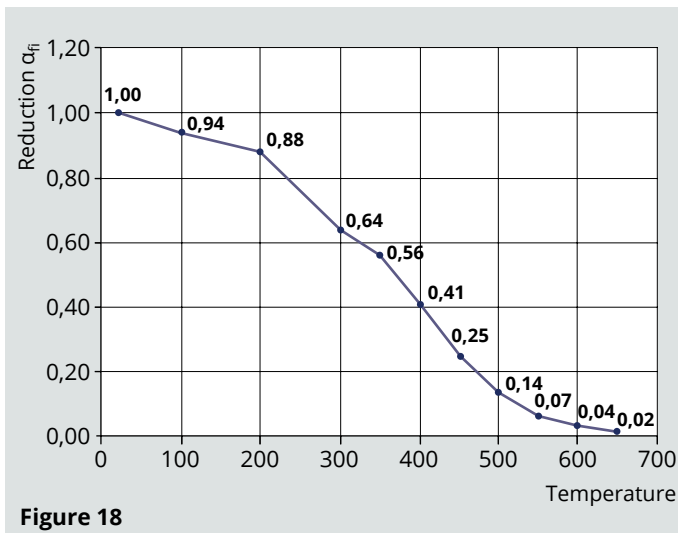
## REI 30 to REI 90-M – proof of limitation of the stress

If  $Z_{Ed,fi}$  and  $v_{Ed,fi,L} \leq 2.5$  kN/m (extraordinary stress combination due to fire, according to approval text) and  $v_{Ed,cold}$  case  $< 60$  kN/m (decisive load case in cold case) then the proof for REI-30 to REI-90M (fire wall) is deemed to have been provided.

## REI 30 to REI 90 – proof of the calculation of the resistance in case of fire

If  $Z_{Ed,fi} \leq 2.5$  kN/m and  $v_{Ed,fi,L} \leq 2.5$  kN/m (extraordinary stress combination), then the dimensioning takes place in accordance with Appendix 13 of the approval.

For the specified fire duration, the temperature at the wire rope loops must be known for the fire situation under consideration (numerical specified simulation or e.g. EN 1992-1-2:2010-12, Fig. A. 2). The temperature is used to determine the reduction factor for the wire rope loop carrying capacity:



**Table 5:** This results in the residual carrying capacity of the wire rope loop:

	Tension [kN/wire rope loop] $Z_{Rd,fi}$	Transversal shear force parallel to the joint [kN] $v_{Rd,fi,II}$
Dimensioning value of the carrying capacity	$Z_{Rd,fi} = \alpha_{fi} \cdot Z_{Rd}^{1)}$	$v_{Rd,fi,II} = \alpha_{fi} \cdot v_{Rd,II}^{2)}$

- <sup>1)</sup>  $Z_{Rd}$  according to Appendix 9, Table 1  
<sup>2)</sup>  $v_{Rd,II}$  according to Appendix 9, Table 2

### Verification of the carrying capacity when exposed to fire

For the verification of supporting connections exposed to fire, the carrying capacities according to Table 5 may be applied. According to the temperature acting on the wire rope loop (e.g. temperature profile EN 1992-1-2:2010-12, Fig. A. 2), the design resistances are to be reduced with  $\alpha_{fi}$ .

Verification of the total tensile force:

$$n \cdot Z_{Rd,fi} \geq Z_{Ed,fi,VI} + Z_{Ed,fi,N}$$

Verification of the shear force parallel:

$$v_{Rd,fi,II} \geq v_{Ed,fi,II}$$

## Proof as a regulated detail 4102-4

In addition to the aforementioned application area, the precast concrete element connections using the VS®-ISI System<sup>3D</sup> can be regarded as equivalent to the connections regulated by DIN 4102-4:2016-05, sections 5.12.5 to 5.12.7.

### Transferable resistances in case of fire:

Building authority fire protection requirements	Fire resistance classes		Resistances of fire-exposed components							
			Proof of limitation of the stress			Proof of the calculation of the resistance in case of fire (Appendix 13)				
			$Z_{Rd}$	$v_{Rd,II}$	$v_{Rd,L}$	$Z_{Rd}$	$v_{Rd,II}$	$v_{Rd,L}$	$Z_{Rd} + v_{Rd,II}$	
	as per DIN 4102	as per EN 13501	2,5 kN/m	$v_{Rd,II}^{1)}$	2,5 kN/m	$Z_{Rd}^{2)}$	$v_{Rd,II}^{2)}$	2,5 kN/m	$Z_{Rd}^{2)}$ + $v_{Rd,II}^{2)}$	
	fire-retardant	F30				REI 30	-	-	-	-
	highly fire-retardant	F60				REI 60	-	-	-	-
	fire-resistant	F90				REI 90	-	-	-	-
Fire wall	Fire wall	REI 90-M	-	-	-	-	-	-		

<sup>1)</sup> fulfilled with the proof in the cold case

<sup>2)</sup> reduced resistances according to approval no. Z-21.8-1929 Appendix 13, Table 6



# Installation instructions

## Manufacture of the precast elements

When a precast element connection is established using the VS®-ISI System<sup>3D</sup>, the casting channel is automatically formed by rail profiles. This means that it is not necessary to provide any additional recessing blocks, depressions or the like. When inserting the VS®-ISI System<sup>3D</sup> into the formwork, it is necessary to ensure that the wire rope ends are threaded as straight as possible between the reinforcements. Starting from the lowest point of the element, the profiles are then simply nailed into place with the loops at the same height for both elements (Fig. 20), or attached with hot-melt adhesive in the case of steel formwork. Fixing the loops to the mesh reinforcement with wire prevents the rails and loops from slipping out of place. The anchorages for the wire rope ends are to be arranged at 90° to the joint.

## After demoulding

The flexible covering foil is simply pulled off after demoulding (Fig. 21). The inside of the VS® profiles is then exposed, and the wire rope loops are visible. The wire rope loop can easily be folded out (Fig. 22). The wire rope loop should protrude perpendicularly from the element, and should spring back to this position again even after having been pushed aside when assembling the elements. The wall components are now ready for final installation on site.

## Assembling the precast elements

The joints, the rail profiles and the loops must be free from dirt or from separative fluids. The wall elements are either placed on a bed of mortar or on levelling plates. The elements must be levelled so that their position and heights are in accordance. Within the framework of the approval, the spacing of the joint may be between 15 mm and 40 mm.

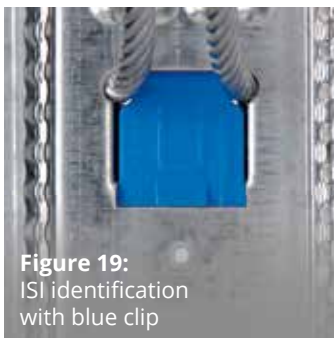


Figure 19:  
ISI identification  
with blue clip

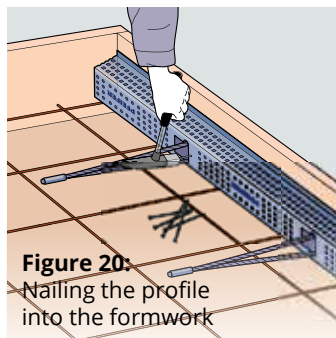


Figure 20:  
Nailing the profile  
into the formwork

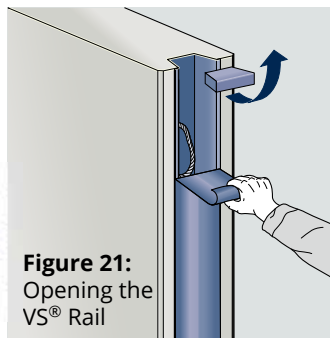


Figure 21:  
Opening the  
VS® Rail

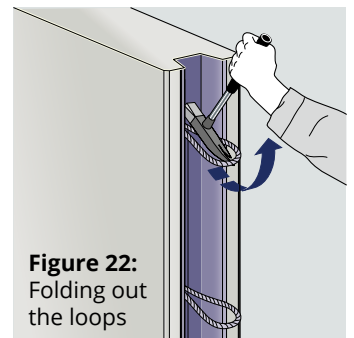


Figure 22:  
Folding out  
the loops



### Note:

In case of installation variants deviating from Fig. 20, PFEIFER Application Consulting must be contacted if **increased formwork pressure** is to be expected as a result. This is the case, for example with upright or battery formwork!

# Installation instructions

## Permissible joint material combinations

		VS®-ISI System <sup>3D</sup> cold case	VS®-ISI System <sup>3D</sup> hot case
<b>PAGEL®</b> <b>Spezialbeton GmbH &amp; Co. KG</b> Wolfsbankring 9 D-45355 Essen Telefon +49 (0) 201 685 040 Telefax +49 (0) 201 685 0431 E-Mail info@PAGEL.com Internet www.PAGEL.com	<b>VS®-PAGEL® grout</b>	✓	✗
	<b>P &amp; T</b> <b>Technische Mörtel GmbH &amp; Co. KG</b> Bataverstraße 84 41462 Neuss Telefon +49 (0) 2131 5669-0 Telefax +49 (0) 2131 5669-22 E-Mail info@eurogrout.de Internet www.eurogrout.de	<b>EuroGrout®Varix</b>	✓
	<b>EuroGrout® universal filler</b>	✓	✓
<b>BETEC®</b> <b>GCP Germany GmbH</b> Alte Bottroper Str. 64 45356 Essen Telefon +49 (0) 201 86147-0 Telefax +49 (0) 201 86147-43 E-Mail info.betec@gcpat.com Internet www.gcpat.de	<b>Betec® VS® grout</b>	✓	✓
	<b>Betec® VS® ThixoTop</b>	✓	✓



### Note:

The manufacturer's information must be observed for processing! You will also find detailed information there regarding processing, and an extensive list of recommended devices. Technical data can also be found in the technical documentation issued by the respective company.

## Grout



- Highly penetrating
- Simple handling
- High design resistance
- No feed pump required
- Even relatively few joints can be filled economically

This high strength and extremely free flowing grout flows perfectly into the recesses of the PFEIFER VS® Systems. As a result there are no strength-limiting faults.

## Joint filling mortar



- Plastic and stable in the joint without formwork
- Less preparatory work is required
- Mixing and conveying can be done in one step
- Pump conveying to the joint

The PFEIFER VS® ISI System<sup>3D</sup> has an optimised profile without unfavourable recesses. It is therefore possible to use a mortar that is plastic/thixotropic and that stands in the joint independently. The big advantage of this is that only very little formwork is needed here. This technology offers significant savings, particularly on large building sites with many metres of joint.

# Installation instructions

## VS® system joint with grout

### Information and notes

The properties of the grout in the joint play an important role in a load-bearing connection of precast concrete elements with the PFEIFER-VS® system elements. The specially developed grouting materials have proven their suitability in combination with the PFEIFER VS® rails system in elaborate tests. These grouting materials are approved within the framework of the building authority approvals.

### Grout properties

- Highly free flowing
- Shrinkage-compensated
- Resistant to frost and de-icing salt
- Can be pumped with mixing and conveying pumps
- Anticorrosive
- Production certified according to DIN ISO 9001
- Delivered as bagged goods (25kg bags)

### Mixing

The material is delivered as a ready-to-pour mixture and only needs to be mixed with water according to the instructions printed on the packaging. The material is then immediately ready to use.

### Joint filling

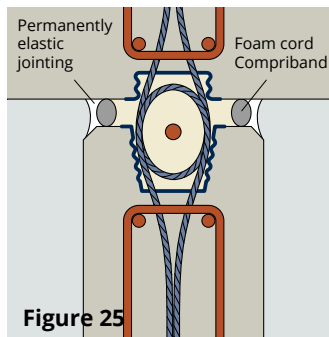
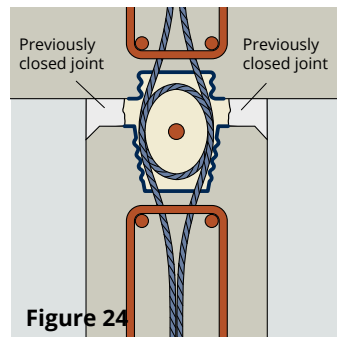
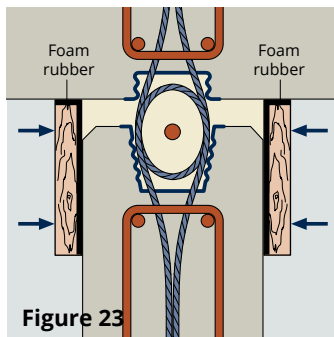
The grout is added continuously until the planned height (max. 3.54 m) is reached. The formwork must be able to withstand the pressure created in this way.

Compaction is not necessary. Nevertheless, air removal by poking with the reinforcing steel or the application of an internal vibrator is recommended. The grout sets very quickly, and allows work to continue promptly. The joint can be subjected to the approved load after the appropriate setting time.



**Caution: the remaining cross section must be at least 14 cm.**

If joint pressure formwork or pre-compressed strips are to be pressed into the side joints without affecting the casting space, the effective lateral concrete coverage of the rail and the wire rope loop is reduced.



### Consumption

The PFEIFER Suite dimensioning software works out the grout volume for the selected grouting joint with the real quantities and masses of the project entered, displays the number of sacks for this.

The table below makes it possible to calculate an estimate of the fully-filled joints; an average grout consumption per metre of joint, based on walls that are 3.5 m high, is given.

**Table 6:** Grout volumes for standard joint (2 mm)

	Wall thickness [cm]					
	14	16	18	20	22	24
VS®-ISI-System <sup>3D</sup>	6,68	7,08	7,48	7,88	8,28	8,68

Consumption in l/m;  
about 2 kg material are required per litre

### Joint formwork variants

#### 1. Board formwork (Fig. 23)

In order to fill a precast joint with grout, a shuttering board needs to be attached from both sides. It is recommended that foam rubber is applied to the shuttering boards in order to compensate for unevenness. When the shuttering boards are properly fastened and it has been ensured that grout material cannot escape anywhere, the joint can be filled as described in the "Joint filling" section. The formwork can be removed, cleaned and reused after the material has hardened.

#### 2. Mortar seal (Fig. 24)

Another variant makes it possible to close the joint flanks with a mortar. After this mortar has hardened, the core of the joint can be filled with grouting material and the higher performance of the systems can be achieved.

#### 3. Sealed off compriband (Fig. 25)

Another way to cast the joints with a grout is the variant sketched in Fig. 25. In this case, prior to grouting, a foam cord/compriband is inserted into the joint in a defined manner, after which a permanently elastic jointing is applied.

When this jointing has completely hardened, the grouting can be carried out without any additional formwork measures. The pressure that arises during grouting must, however, be borne in mind. This should be determined by the processing company, allowing suitable grouting sections to be chosen to avoid the jointing from being pushed out.

# Installation instructions

## VS® system joint with plastic/thixotropic joint filling mortar

### Information and notes

The advantage of the joint filling mortar is the filling of joints between precast elements, where formwork can mostly be dispensed with. The optimised, plastic/thixotropic properties of this mortar means that it is stable after being poured in the joint, without the need for further measures. The associated approval governs tensile and shear forces parallel and vertical to the joint.

### Mortar properties

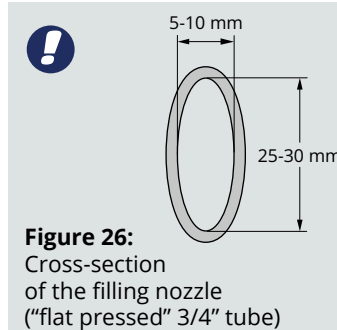
- Non-shrinking, with a gel-like consistency
- Easy preparation
- Can be pumped with conventional worm pumps
- High early and final strengths
- Resistant to frost and de-icing agents
- Impermeable to water
- Low water/cement ratio
- Production certified according to DIN ISO 9001
- Monitored externally and in-house
- Delivered as bagged goods (25 kg bags)

### Mixing

The mortar is supplied ready to use, and only has to be mixed with water before use. It is essential that the mixing instructions on the bags are observed.

### Nozzle making

The user can make the filling nozzle from commercially available 22 mm (3/4") copper heating pipe. It can be attached to the pump hose with the aid of a solder fitting (Figs. 26 and 27).



#### Note:

This information only concerns the introduction of the material into the joint!



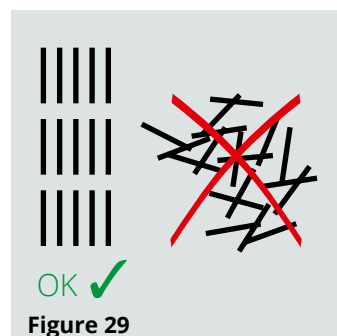
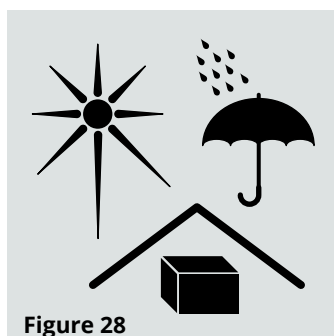
#### Caution: do not constrict the filling space.

If pre-compressed strips are to be pressed into the side joints without affecting the casting space, the effective lateral concrete coverage of the rail and the wire rope loop is reduced. This must also be taken into account by the planners in the dimensioning.

### Qualification

Suitable machinery and instructed personnel are important for the quality and efficiency of the mortar system. If necessary, instructions can be requested at any time from the mortar manufacturers.

### Storage



# PFEIFER Suite dimensioning software

The approved PFEIFER-VS® rail systems can be easily planned on precast wall joints with the aid of the free dimensioning software. The latest version of the software is available to download from the Internet at [www.pfeifer.info](http://www.pfeifer.info). Your additional benefits when using the software are:

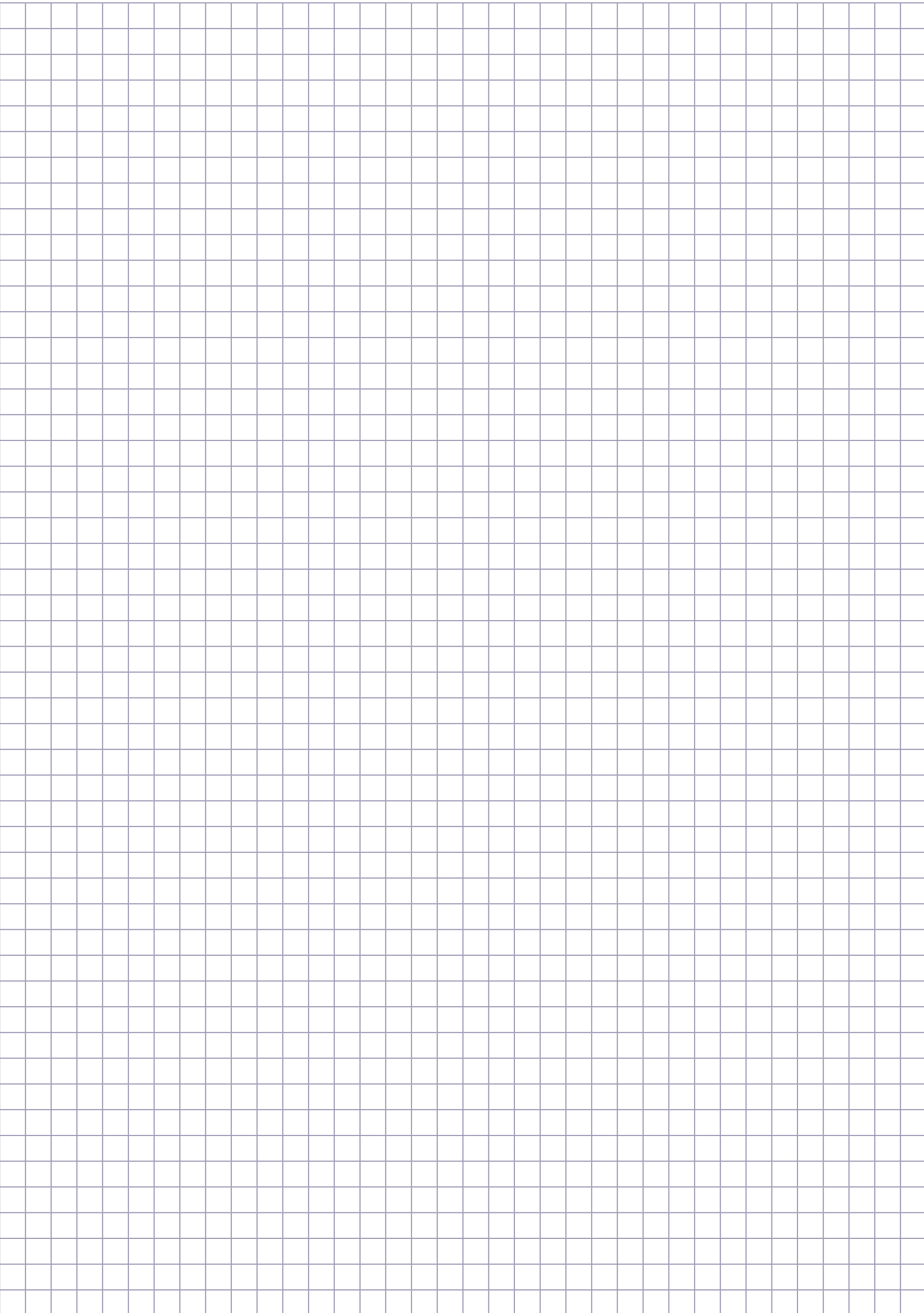
- Permanently storable processor data and one-off project data
- Automatic quantity calculation for a complete project – mortar (litres and dry quantity) and VS® product
- Automatic verification of the connection
- Generation of a complete mathematical verification
- Calculations for the widest range of applications:
  - Wall-wall joint
  - Wall-column joint
  - Wall-corner
  - Wall panel complete
  - with constant and changing loads
  - with shear force parallel and perpendicular
  - with tensile forces
- Integrated fire protection verification



The latest version of the software is available to download at [www.pfeifer.info/de/firmengruppe/geschaeftsbereiche/bautechnik/pfeifer-bemessungssoftware/](http://www.pfeifer.info/de/firmengruppe/geschaeftsbereiche/bautechnik/pfeifer-bemessungssoftware/).



# Notes



# Notes





# PFEIFER

International

Sales

+49 (0) 83 31-937-231

Technical Support

+49 (0) 83 31-937-345

[export-bt@pfeifer.de](mailto:export-bt@pfeifer.de)

[www.pfeifer.info/concrete-inserts](http://www.pfeifer.info/concrete-inserts)