

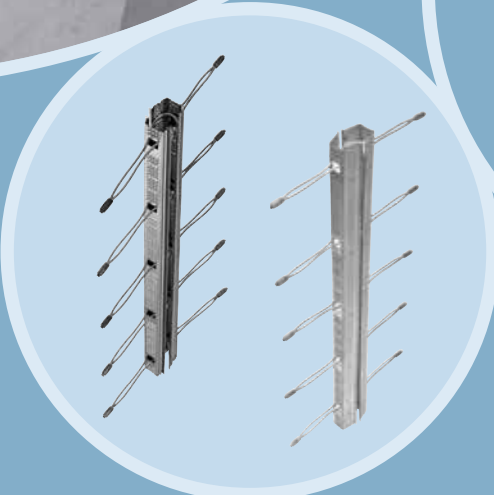

Constructive VS[®] rail systems

PFEIFER



planning & installation

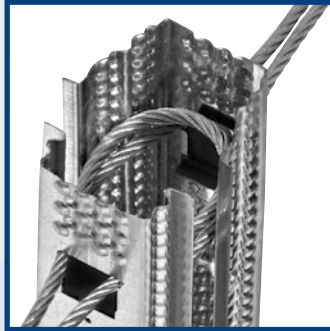

The VS[®] Rail T 50 and the Long Box T 20 offer an optimum casting channel for your column-wall connection



Efficiency

- Butt and T wall joints, as well as wall-column connections – implement wall joints economically, simply and securely
- Rail profile acts simultaneously as formwork – no additional wooden formwork needed
- No additional tools necessary



Innovation

- Optimum loop overlapping through fixed geometry
- Lateral profiling ensures firm hold in the ground



Symmetry

- Non-directional installation necessary
- Practical and reliable



Quality

- Every application occurring in reality i covered
- Robust, galvanized steel sheet strip
- Loops protected in the rail when folded out

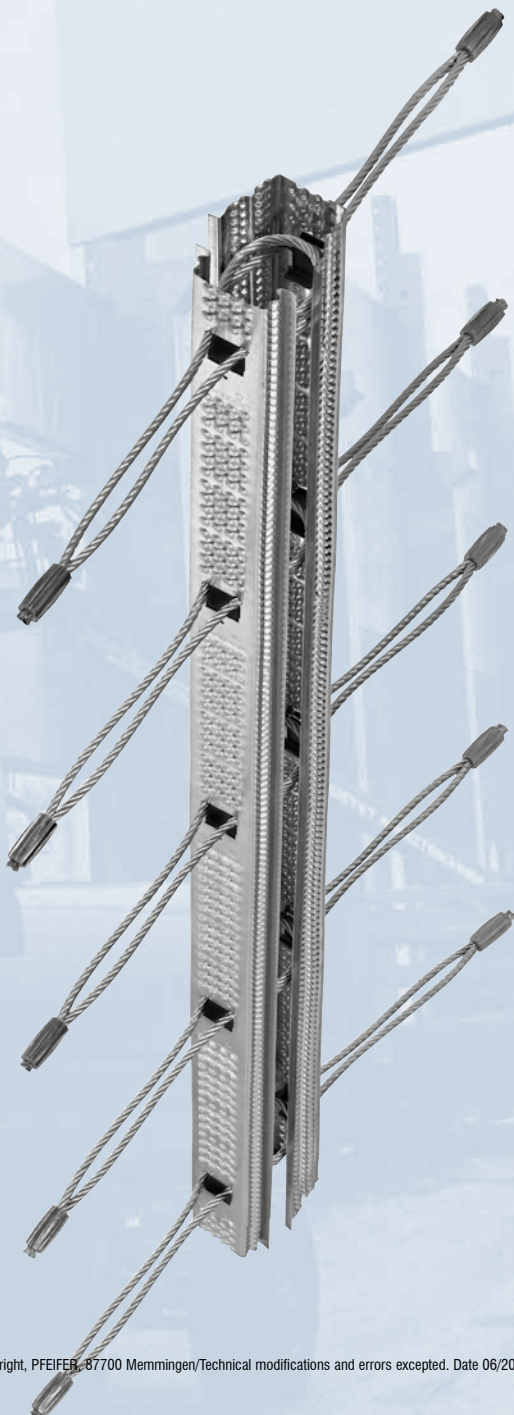

PFEIFER VS[®] Rail T20

PFEIFER VS[®] Long Box T50

Item no. 05.030

Item no. 05.027

For non-load bearing wall and column connections in precast construction



PFEIFER

Reinforcement Systems

VS[®] System

The PFEIFER T20 and T50 rails and strips are used for non-load bearing connection of precast wall panels and columns as well as for wall/wall connections.

Casting materials and joint filling mortar with plastic/thixotropic properties can be used as the joint filling material.

Grout is a self-compacting, very free-flowing material. With the help of joint formwork it is possible to grout an entire storey of a building.

Joint filling mortar is a plastic joint material that remains firmly in the joint after insertion without elaborate formwork.

Materials:

Rails: Steel sheet galvanized

Steel rope: high-strength, galvanized

Cover: Tape

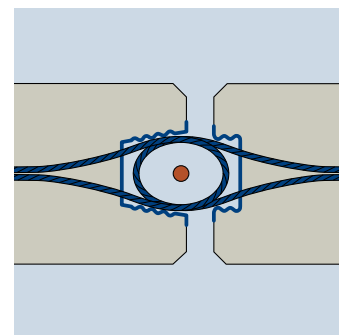
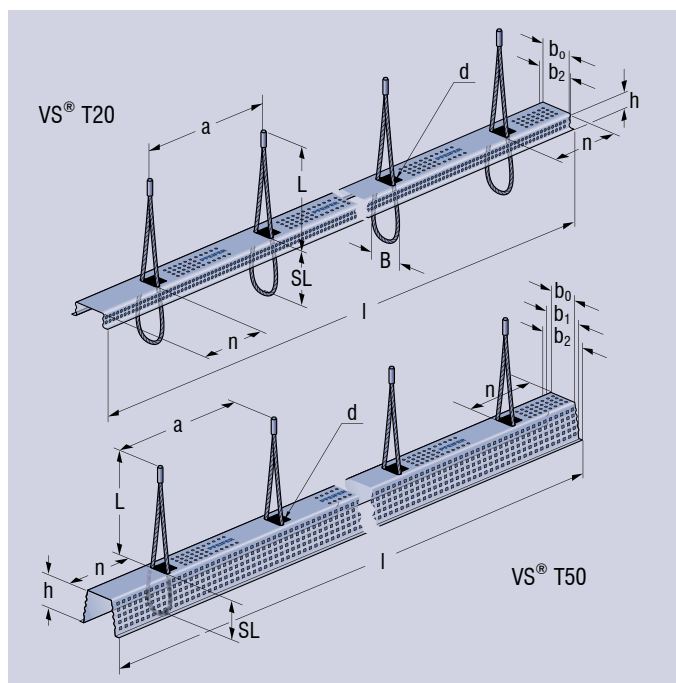

Ref.-No.	Type/size	Dimensions [mm]											Loops Quantity	Colour clip	Packing unit/pieces	Weight approx. kg/piece
		b ₀	b ₁	b ₂	h	l	SL	L	a	n	B	d				
286802	VS [®] -T20/2	50	-	70	20	1180	75	205	590	295	60	3	2	black	100	0,88
286803	VS [®] -T20/4	50	-	70	20	1180	75	205	295	148	60	3	4	black	100	1,08
286804	VS [®] -T20/6	50	-	70	20	1180	75	205	186	125	60	3	6	black	100	1,40
286805	VS [®] -T20/7	50	-	70	20	1180	75	205	155	125	60	3	7	black	100	1,70
286798	VS [®] -T50/2	50	65	80	50	1180	75	205	590	295	60	3	2	black	60	1,15
286799	VS [®] -T50/4	50	65	80	50	1180	75	205	295	148	60	3	4	black	60	1,35
286800	VS [®] -T50/6	50	65	80	50	1180	75	205	186	125	60	3	6	black	60	1,75
286801	VS [®] -T50/7	50	65	80	50	1180	75	205	155	125	60	3	7	black	60	1,90
287840	VS [®] -T20/0	50	-	70	20	1180	-	-	-	-	-	3	-	-	150	0,68
287786	VS [®] -T50/0	50	65	80	50	1180	-	-	-	-	-	3	-	-	150	1,00



Lateral rail profiling
ensures firm hold!



The PFEIFER-VS[®] Rail W50 – implement wall joints economically, simply and securely



Efficiency

- Comprehensive range for all applications
- Fast, efficient assembly using materials by the metre
- Simple fabrication of one storey height casting channel



Innovation

- Lateral rail profiling ensures firm hold in the concrete – even during demoulding



Symmetry

- Non-directional installation necessary
- Practical and reliable



Quality

- Strong, convenient steel sheet box for any desired configuration
- The rails can be separated or shortened easily
- Optimum joint casting due to simple rail geometry



PFEIFER VS[®] Rail T50

Item no. 05.027



PFEIFER

Connecting elements
VS[®] Rail

The PFEIFER-VS[®] Rail W50 is used for non-load-bearing connections between concrete elements. Wall joints can be produced economically, easily and safely. The length of the wire rope loops is matched to the rail profile so that optimum connection conditions are achieved in the casting channel.

The trapezoidal rail guarantees secure, easy casting of the joint over the entire height of the storey.

Both casting mortar and plastic/thixotropic materials can be used as the filling material.

Casting is particularly fast and effective with the help of the FDS VS[®] Joint Pressure Formwork.

Materials:

Box: Steel sheet, galvanized
Steel rope: high-strength, galvanized
Steel ferrule
Cover: Tape

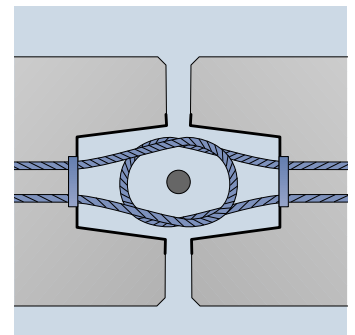
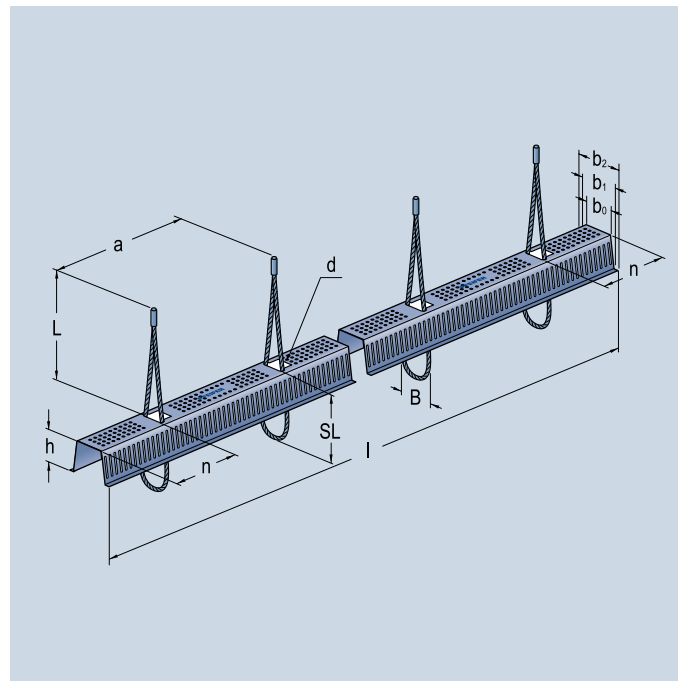

Ref.-No.	Type/size	Dimensions [mm]											Loops Quantity	Colour clip	Packing unit/pieces	Weight approx. kg/piece
		b ₀	b ₁	b ₂	h	l	SL	L	a	n	B	d				
286806	VS [®] -W50/2	50	65	80	50	1180	100	180	590	295	60	3	2	white	60	1,15
286807	VS [®] -W50/4	50	65	80	50	1180	100	180	295	148	60	3	4	white	60	1,35
286808	VS [®] -W50/6	50	65	80	50	1180	100	180	186	125	60	3	6	white	60	1,75
286809	VS [®] -W50/7	50	65	80	50	1180	100	180	155	125	60	3	7	white	60	1,90
287786	VS [®] -W50/0	50	65	80	50	1180	-	-	-	-	-	3	-	-	150	1,00

General installation instructions for VS[®] rail systems

Use

The PFEIFER-VS[®] rail systems are provided for the connection of reinforced concrete precast wall elements (Figures 2 to 5), or walls and columns made of concrete of grade C30/37 or better. The systems always consist of the VS[®] profiled rails and a suitable grouting material.

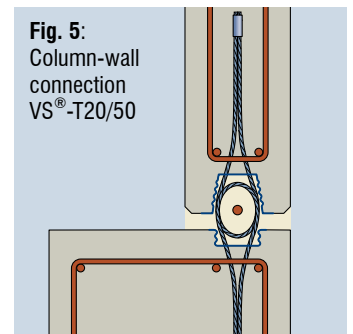
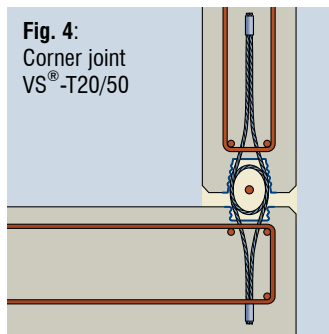
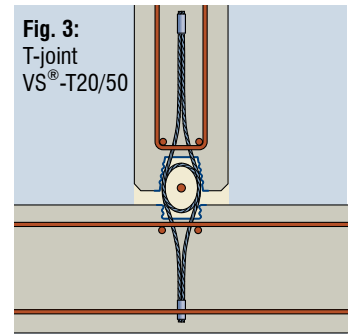
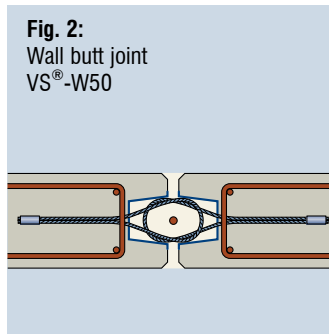
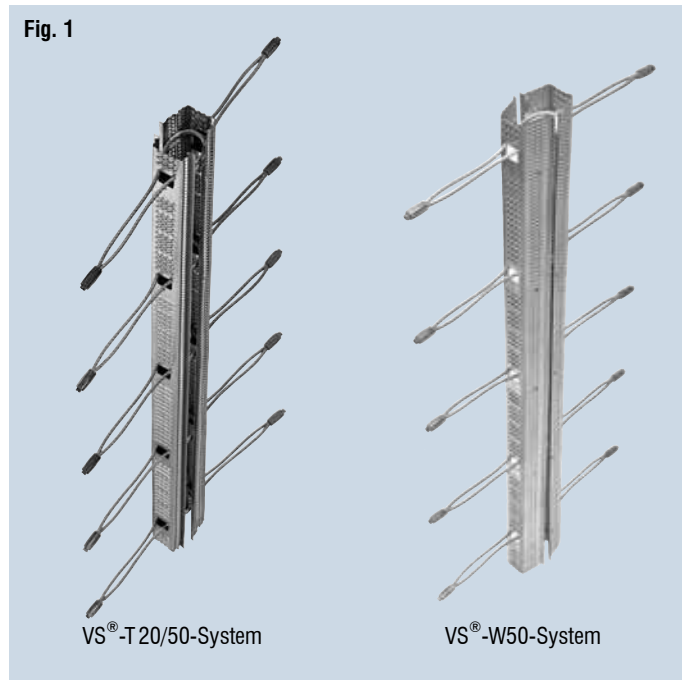

Dimensioning



Notice: It is strongly recommended that the VS[®]-ISI / VS[®]-BZ 50 rails are used in accordance with national regulations for static load-bearing connections.

Installation and usage

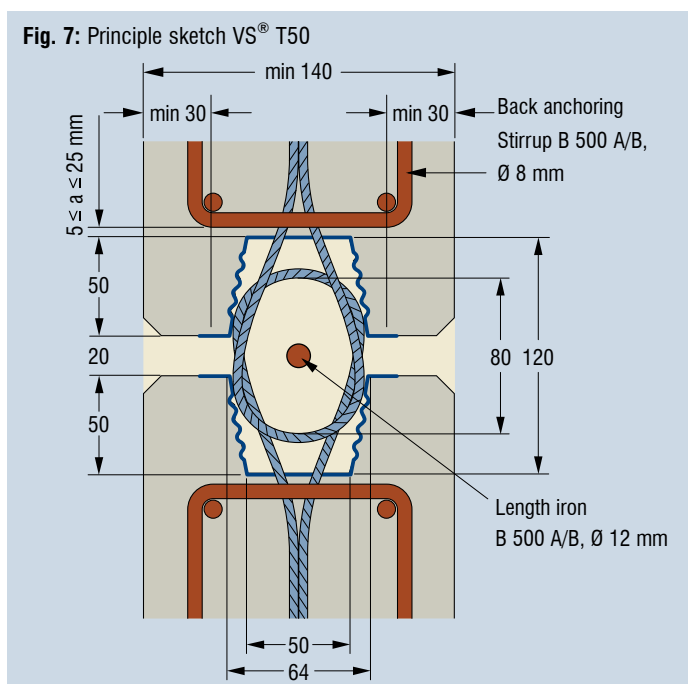
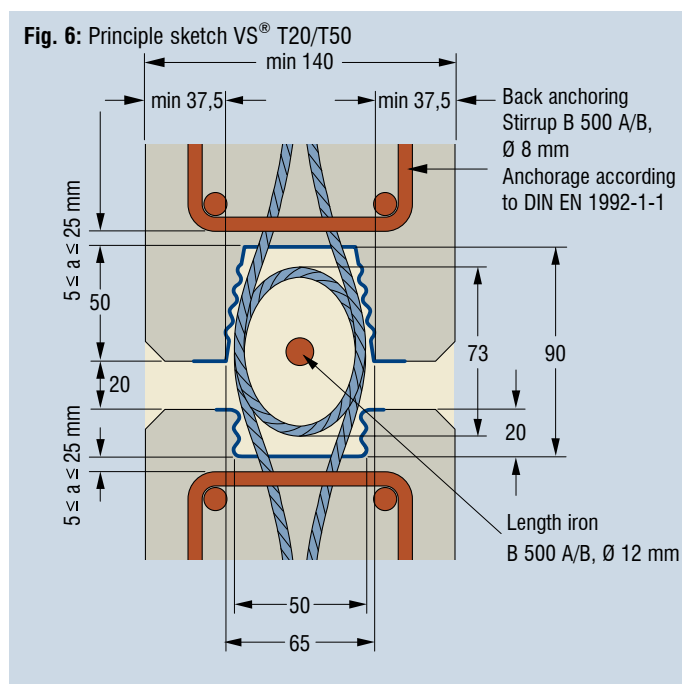

Installation and usage

Bending the anchoring loop

When the elements have small dimensions, the anchoring loop of the VS® Long Boxes can be bent. The crucial factor here are the bending dimensions given, for example, in Figures 8 to 10. At a corner joint, a $\varnothing 8$ mm stirrup is recommended in the region of the bent loop.

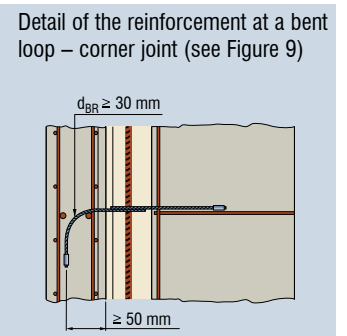
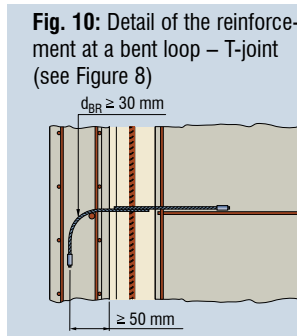
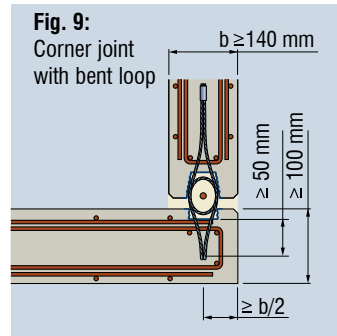
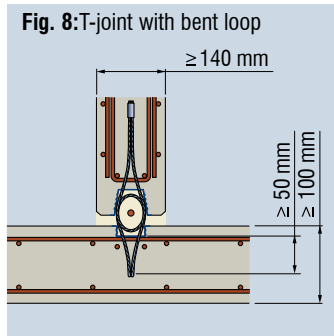

Reinforcement

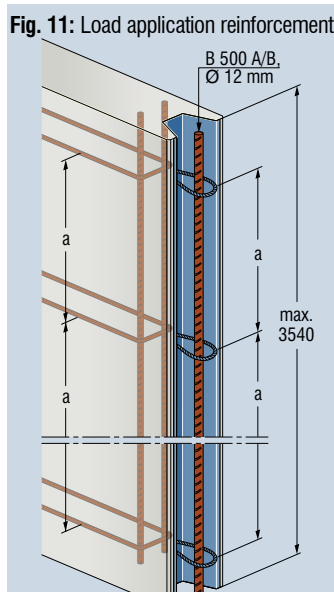

Reinforcement according to Figures 6, 7 and 11 is recommended in the reinforced concrete precast elements for the VS® rail systems. Other national regulations have local priority over this recommendation, and if they exist it is essential that they are observed.

! Notice: As an alternative to the stirrups, a suitable mesh cap can also be installed.

Element joints

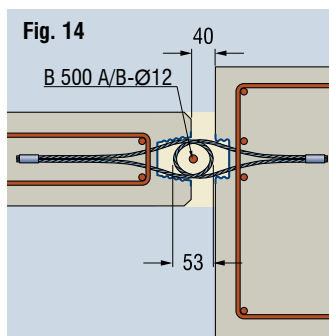
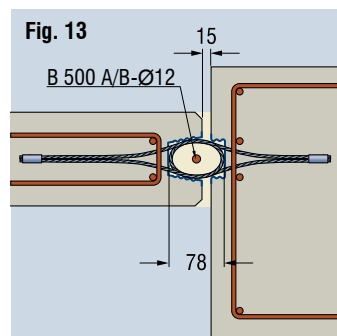
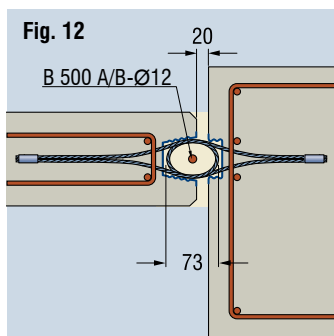

Standard joint = 20 mm (Figure 12)
Minimum joint = 15 mm (Figure 13)
Maximum joint = 40 mm (Figure 14)

Installation tolerances

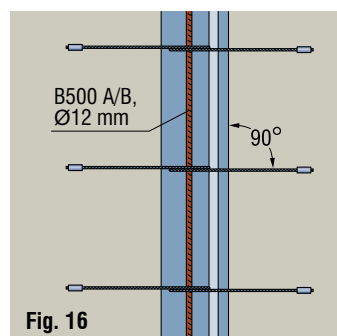
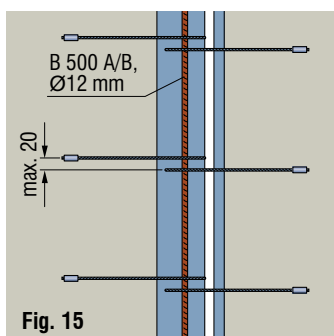

The planning must not provide for any offsets between the loops over the length of the joint. The loops must therefore be installed in such a way that they are in contact and lie directly on top of one another (Figure 16). If the joints extend over a number of floors, it may in some circumstances be useful to set regular zero points for orientation of the rail sections. Maximum vertical height tolerance from standard construction variations of 20 mm is admissible (Figure 15).

! Notice: Due to the symmetric arrangement of the loops in the variants with 6 and 7 loops, there is a larger spacing of the loops in the joint between two profiles.

Manufacture of the steel reinforced concrete precast elements

When a precast element connection is established using the VS[®] Rail and Long Box system, the casting channel is automatically formed by rail profiles. This means that it is not necessary to provide any additional recessing blocks, depressions or equivalent. When inserting the VS[®] profiles into the formwork, it is necessary to ensure that the wire rope ends are threaded as straight as possible between the reinforcement. Starting from the lowest point of the element, the profiles are then simply nailed into place with the loops at the same height for both elements (Figure 18), or attached with hot-melt adhesive in the case of steel formwork. Fixing the loops to the mesh reinforcement with wire prevents the rails and loops from slipping out of place. The anchorages for the wire rope ends are to be arranged at 90 ° to the joint. They are to be positioned in such a way that the heights of facing loops correspond precisely.



Fig. 17:
W50 identification
with white clip

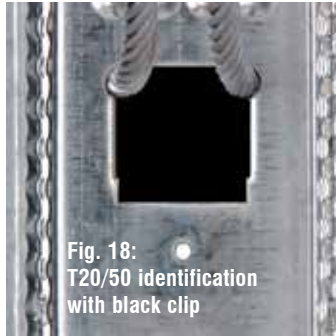

Fig. 18:
T20/50 identification
with black clip



Caution: Install the rails in the two elements that are to be joined with the loops at the same height. Profiles with different clip colours may not be combined.

After demoulding

The flexible covering tape is simply pulled off after demoulding (Figure 19). The inside of the VS[®] profiles is then exposed, and the wire rope loops are visible. The wire rope loop can easily be folded out (Figure 20). The wire rope loop should protrude perpendicularly from the element, and should spring back to this position again even after having been pushed aside when assembling the elements. This is important in order to ensure the correct overlap. The wall components are now ready for final installation on site.

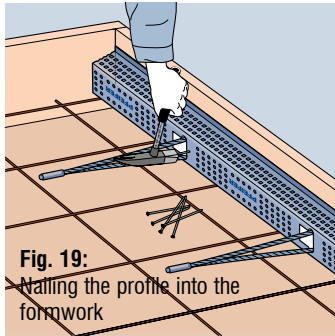

Fig. 19:
Nailing the profile into the
formwork

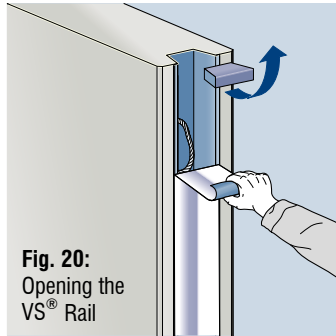

Fig. 20:
Opening the
VS[®] Rail

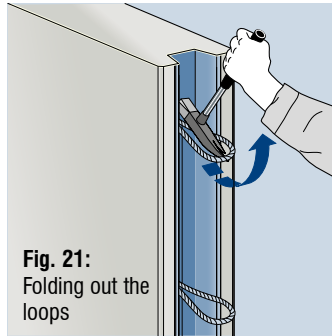

Fig. 21:
Folding out the
loops



Notice: PFEIFER application consultation service should be consulted if **increased formwork pressure** is to be expected as a result of vertical formwork.

Assembling the precast elements

The joints, the rail profiles and the loops must be free from dirt or from separative fluids. With the permitted connection method, the wall elements are either placed on a bed of mortar or on levelling plates. The elements must be levelled so that their position and heights are in accordance. Within the framework of the approval, the spacing of the joint may be between 15 mm and 40 mm. Vertically, the opposite loops should overlap touching or with a maximum spacing of 20 mm.

Permitted VS[®] rails and joint material combinations

		VS [®] T20/T50	VS [®] W50
PAGEL[®] Spezialbeton GmbH & Co. KG Wolfbankring 9 D-45355 Essen Phone +49 (0) 201 685 040 Fax +49 (0) 201 685 0431 E-mail info@PAGEL.com Internet www.PAGEL.com	VS [®] -PAGEL [®] grout	✓	✓
	VS [®] -P PAGEL [®] joint filling mortar	✓	✓
P & T Technische Mörtel GmbH & Co. KG Bataverstrasse 84 41462 Neuss Phone +49 (0) 2131 5669-0 Fax +49 (0) 2131 5669-22 E-mail info@eurogrout.de Internet www.eurogrout.de	EuroGrout [®] Varix	✓	✓
	EuroGrout [®] universal filler	✓	✓
BETEC[®] GCP Germany GmbH Alte Bottroper Str. 64 45356 Essen Phone +49 (0) 201 86147-0 Fax +49 (0) 201 86147-43 E-mail info.betec@gcpat.com Internet www.gcpat.de	Betec [®] VS [®] grout	✓	✓
	Betec [®] VS [®] thixotropic	✓	✓



Notice:

The manufacturer's information must be observed for processing! You will also find detailed information there regarding processing, and an extensive list of recommended devices. Technical data can also be found in the technical documentation issued by the respective company.

Grout



- Highly penetrating
- Simple handling
- High design resistance
- No feed pump required
- Even relatively few joints can be filled economically

This high strength and extremely free flowing grout flows perfectly into the recesses of the PFEIFER VS[®] systems. As a result there are no strength-limiting faults. In combination with the PFEIFER-VS[®] FDS Joint Pressure Formwork, this mortar makes it possible to fabricate extremely high-quality joint casting quickly and securely. The material can also be used with VS[®] rail systems.

Joint filling mortar



- Plastic and stable in the joint without formwork
- Less preparatory work is required
- Mixing and conveying can be done in one step
- Pump conveying to the joint

The PFEIFER-VS[®] rail systems have an optimised profile without awkward depressions. It is therefore possible to use a mortar that is plastic/thixotropic and that stands in the joint independently. The big advantage of this is that only very little formwork is needed here. This technology offers significant savings, particularly on large building sites with many metres of joint.

VS® system joint with grout

Information and notes

The properties of the grout in the joint play an important role in a load-bearing connection of precast concrete elements with the PFEIFER-VS® system elements. The specially developed grouting materials have proven their suitability in combination with the PFEIFER VS® rails system in elaborate tests. These grouts are approved within the framework of the building authority approvals.

Grout properties

- ✓ Highly free flowing
- ✓ Shrinkage-compensated
- ✓ Resistant to frost and de-icing salt
- ✓ Can be pumped with mixing and conveying pumps
- ✓ Corrosion inhibiting
- ✓ Production certified according to DIN ISO 9001
- ✓ Delivered as bagged goods (25 kg bags)

Mixing

The material is delivered as a ready-to-pour mixture and only needs to be mixed with water according to the instructions printed on the packaging. The material is then immediately ready to use.

Joint filling

The grout is added continuously until the planned height (max. 3.54 m) is reached. The formwork must be able to withstand the pressure created in this way. Compaction is not necessary. Nevertheless, air removal by poking with the reinforcing steel or the application of an internal vibrator is recommended. The grout sets very quickly, and allows work to continue promptly. The joint can be subjected to the approved load after the appropriate setting time.

Consumption

The PFEIFER Suite dimensioning software calculates the grout volume for the selected grouting joint with the real quantities and masses of the project and displays the number of bags.

The table below makes it possible to calculate an estimation of the fully-filled joints; an average grout consumption per metre of joint, based on walls that are 3.5 m high, is given.

Table 6: Grout volumes for standard joint (2 mm)

	Wall thickness [cm]					
	14	16	18	20	22	24
VS® T20/T50	6.68	7.08	7.48	7.88	8.28	8.68
VS® W50	8.50	8.90	9.30	9.70	10.10	10.50

Consumption in l per m;
about 2 kg material are required for each litre

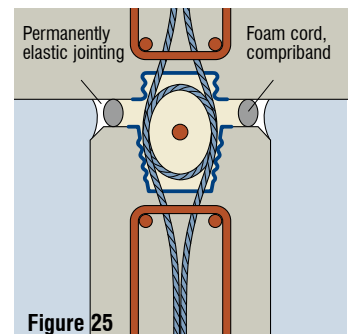
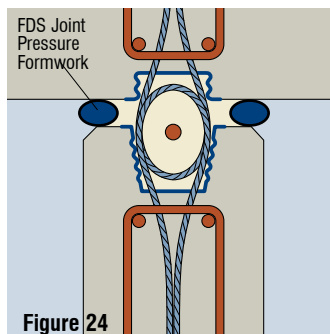
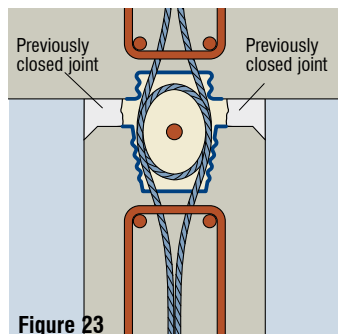
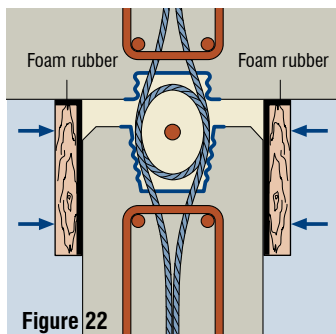

Joint formwork variants

1. Board formwork (figure 22)

In order to fill a precast joint with grout, a shuttering board needs to be attached from both sides. It is recommended that foam rubber is applied to the shuttering boards in order to compensate for unevenness. When the shuttering boards are properly fastened and it has been ensured that grout material cannot escape anywhere, the joint can be filled as described in the "Joint filling" section. The formwork can be removed, cleaned and reused after the material has hardened.

2. Mortar seal (figure 23)

Another variant makes it possible to close the joint flanks with a mortar. After this mortar has hardened, the core of the joint can be filled with grouting material and the higher performance of the systems can be achieved.

3. VS® FDS Joint Pressure Formwork (figure 24)

The joint pressure formwork consists of two hoses, 4 m long. These are very slightly pumped up, and pressed into the slot of the joint, so that the casting space of the loops is not impaired. After the hose has been inserted over the full height of the joint, the hoses are brought up to the rated pressure, and the joint is sealed. The joint grouting can now be poured in from above, over the full height of 3.54 m. After the grout has hardened, the air pressure can be released and the hose removed. It can be reused after cleaning.

4. Sealed off compriband (figure 25)

Another way to cast the joints with a grout is the variant sketched in Figure 25.

In this case, prior to grouting, a foam cord/compriband is inserted into the joint in a defined manner, after which a permanently elastic jointing is applied.

When this jointing has completely hardened, the grouting can be carried out without any additional formwork measures. The pressure that arises during grouting must, however, be borne in mind. This should be determined by the processing company, allowing suitable grouting sections to be chosen to avoid the jointing from being pushed out.



Caution: The remaining cross section must be at least 14 cm. If joint pressure formwork or pre-compressed strips are to be pressed into the side joints without affecting the casting space, the effective lateral concrete coverage of the rail and the wire rope loop is reduced.

VS[®] system joint with plastic/thixotropic joint filling mortar

Information and notes

The advantage of the joint filling mortar is the filling of joints between precast elements, where formwork can mostly be dispensed with. The optimised, plastic/thixotropic properties of this mortar means that it is stable after being poured in the joint, without the need for further measures. The associated approval governs tensile and shear forces parallel and vertical to the joint.

Mortar properties

- ✓ Non-shrinking with gel-type consistency
- ✓ Easy preparation
- ✓ Can be pumped with conventional screw pumps
- ✓ High early and final strengths
- ✓ Resistant to frost and de-icing agents
- ✓ Impermeable to water
- ✓ Low water/cement ratio
- ✓ Production certified according to DIN ISO 9001
- ✓ Monitored externally and in-house
- ✓ Delivered as bagged goods (25 kg bags)

Mixing

The mortar is supplied ready to use, and only has to be mixed with water before use. It is essential that the mixing instructions on the bags are observed.

Joint filling

First completely close off one joint flank using foam cord, profiled rubber (Figure 26) or alternatively using joint filling mortar (Figure 27). After closing with joint filling mortar, wait for the mortar to become stiff. After this, working from the other side, the remaining joint, which is now closed on one side, should be filled from the bottom to the top evenly and continuously. Gently poking the joint with the filling nozzle or the filling pipe ensures a proper result. The joint can easily be drawn flat after having been filled.

Joint formwork variants

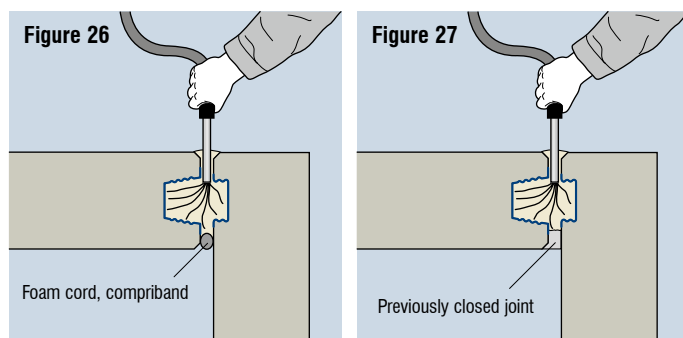

Storage

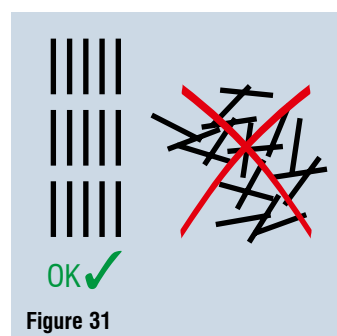
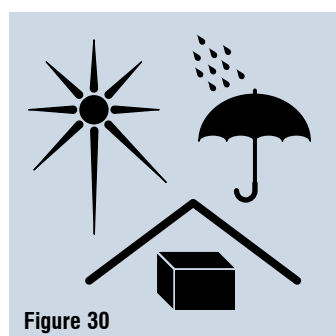

Nozzle making

The user can make the filling nozzle from commercially available 22 mm (3/4") copper heating pipe. It can be attached to the pump hose with the aid of a solder fitting (Figures 28 and 29).

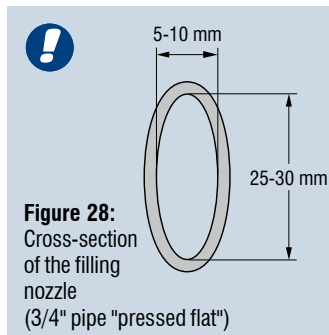

! **Notice:** This information only concerns the introduction of the material into the joint!

! **Caution: do not constrict filling space.** If pre-compressed strips are to be pressed into the side joints without affecting the casting space, the effective lateral concrete coverage of the rail and the wire rope loop is reduced. This must also be taken into account by the planners in the dimensioning.

Qualification

Suitable machinery and instructed personnel are important for the quality and efficiency of the mortar system.

If necessary, instructions can be requested at any time from the mortar manufacturers.



PFEIFER

International

Sales

+49 (0) 83 31-937-231

Technical Support

+49 (0) 83 31-937-345

export-bt@pfeifer.de

www.pfeifer.info/concrete-inserts

© moodboard | Cover: fotolia